

# IR Receiver Modules for Remote Control Systems

## Description

The **FM-2238SMH-5DN** series are miniaturized receiver for infrared remote control system. The PIN Photodiode and preamplifier are assembled on lead frame. The epoxy package is designed as IR filter. The module has excellent performance even in disturbed ambient light application and provides protection against uncontrolled output pulses.

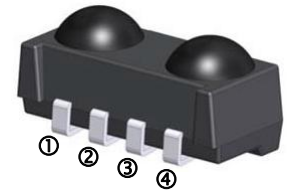

①GND ②V<sub>CC</sub>  
③V<sub>OUT</sub> ④GND

## Features

- Surface Mount Package.
- Supply Voltage Range: 2.7V to 5.5 V
- Supply Current : 0.35mA
- Epoxy IR filter characteristic : 940nm
- Maximum interference safety against optical and electrical disturbance.
- Internal filter for a high frequency lighting fluorescent lamp.
- Internal Pull-Up output.
- Meet RoHS

## Application Circuit

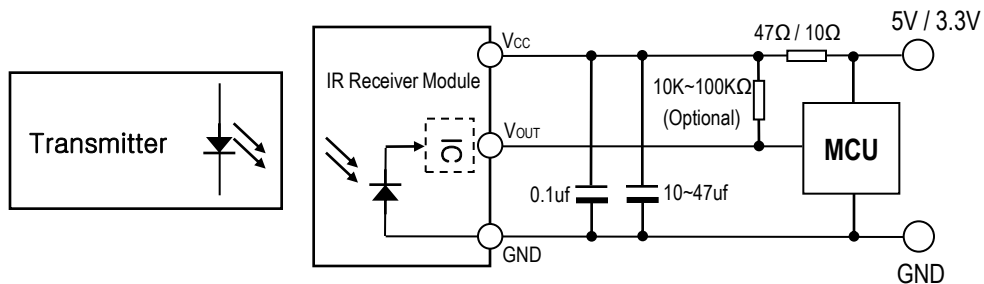

R-C filter recommended to suppress power supply disturbances.  
R-C filter should be connected closely between V<sub>CC</sub> pin and GND pin.

## Block Diagram

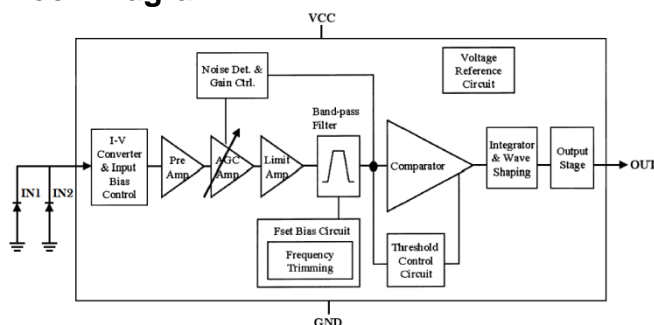

## B.P.F Center Frequency

Model No.	Carrier Frequency (fo)
FM-2236SMH-5DN	36.7 KHz
FM-2238SMH-5DN	37.9 KHz
FM-2240SMH-5DN	40.0 KHz

**Suitable Data Format**

NEC code	◆	Sony 15bit	◆	RCS-80 code	◇
RC5 code	◆	Sony 20bit	◇	Sharp code	◇
RC6 code	◆	RCMM code	◇	High data rate code	◇
Sony 12 bit	◆	RCA code	◇	Disturbance suppression	◆

Note : ◆ : Suitable for this IR code ; ◇ : Not recommended

**Absolute Maximum Ratings**

(Ta = 25°C)

Parameter	Symbol	Ratings	Unit
Supply Voltage	V <sub>CC</sub>	6.5	V
Output Current	I <sub>sink</sub>	2.0	mA
Operating Temperature	T <sub>opr</sub>	-20 ~ +80	°C
Storage Temperature	T <sub>stg</sub>	-30 ~ +85	°C
Soldering Temperature	T <sub>sd</sub>	260°C, Max 5 sec	°C

**Electro-optical Characteristics**

(Ta = 25°C)

Parameter	Symbol	Min.	Typ.	Max.	Unit	Conditions	
Supply Current	ICC	0.2	0.35	0.45	mA	No signal input	
Output Voltage	V <sub>oh</sub>	V <sub>CC</sub> -0.5	-	-	V	No external pull-up resistor (I <sub>sink</sub> < 1mA)	
	V <sub>ol</sub>	-	0.2	0.4	V		
Peak Wave Length	λ <sub>p</sub>	-	940	-	nm		
Internal Pull-up Resistor	R <sub>pul</sub>	-	40	-	kΩ		
Arrival Distance	L	±0°	-	20	-	m	Fig 1,2,3
		±30°	-	15	-	m	
		±45°	-	10	-	m	
Output Pulse width	T <sub>pw</sub>	400	600	800	us	Burst Wave =600us Period = 1.2ms	

Note :

- 1) Arrival Distance Effected by Environment
- 2) While the device is operational across the temperature range, functionality will vary with temperature.  
Specifications are stated only at 25°C unless otherwise noted.
- 3) Stresses beyond those listed under "absolute maximum ratings" may cause permanent damage to the device.  
These are stress ratings only, and functional operation of the device at these or any other conditions beyond those indicated under "recommended operating conditions" is not implied.  
Exposure to absolute-maximum-rated conditions for extended periods may affect device reliability.

[ Fig.1 ] Data Signal diagram

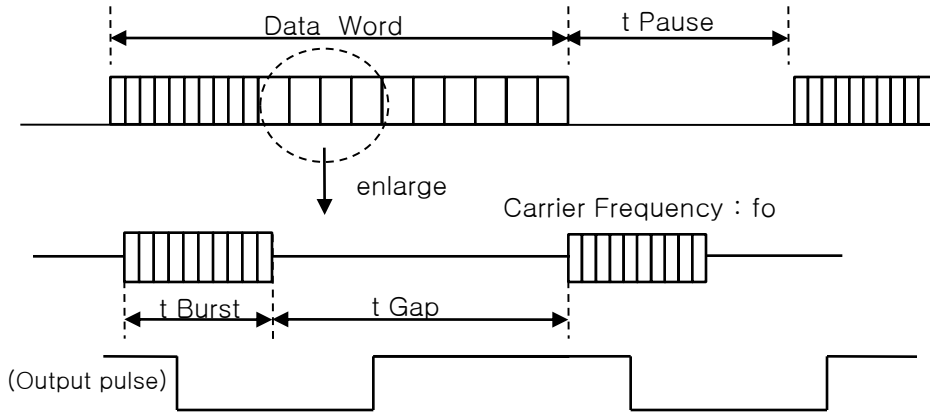

- $t_{Gap}$  : Signal gap time between two burst in pulses of carrier. Minimum Gap Time  $\geq 20$  pulses
- $t_{Burst}$  : Length of a burst in pulses of the carrier frequency. Minimum Burst  $\geq 15$  pulses
- $t_{pause}$  : Data pause between two data words. Minimum Data Pause Time  $\geq 25ms$

[ Fig.2 ] Transmitter

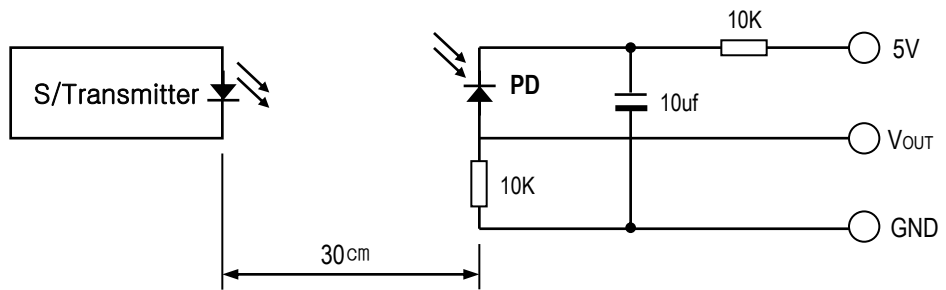

※ The specifications shall be satisfied under the following conditions. The standard transmitter shall be specified of the burst wave form adjusted to  $V_{out}$  200mVp-p upon  $P_o$  measuring circuit Standard Transmitter

[ Fig.3 ] Test condition of arrival distance

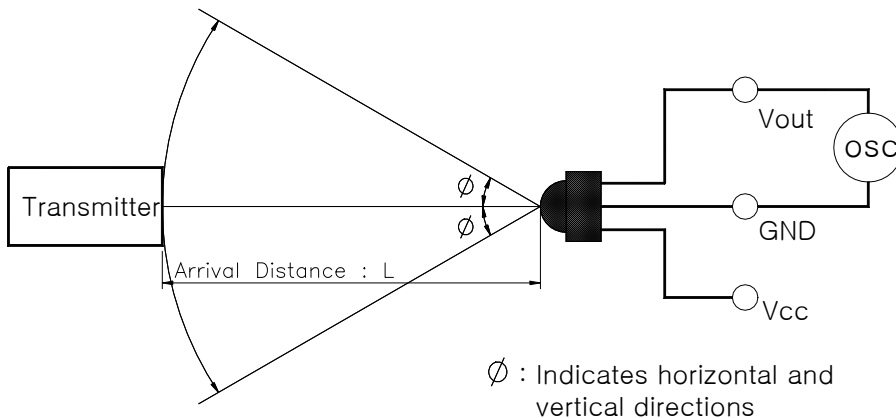

[ Measurement condition for arrival distance ]

☞ Ambient light source : Detecting surface illumination shall be irradiate 200 Lux under ordinary white fluorescence lamp without high frequency lighting

Electrical/Optical Characteristics

[ Fig.4 ] Supply Current vs. Voltage

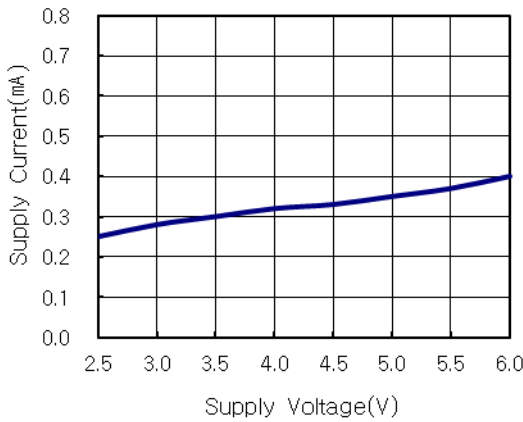

[ Fig.5 ] Relative Spectral Sensitivity vs. Wavelength

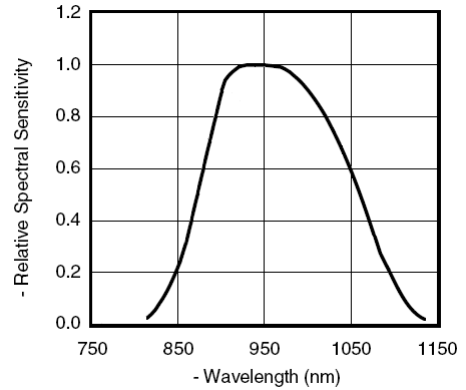

[ Fig.6 ] Sensitivity vs. Supply Voltage

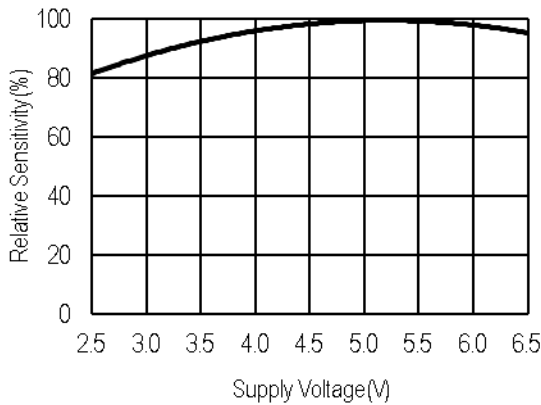

[ Fig.7 ] Directivity (Horizontal/Vertical)

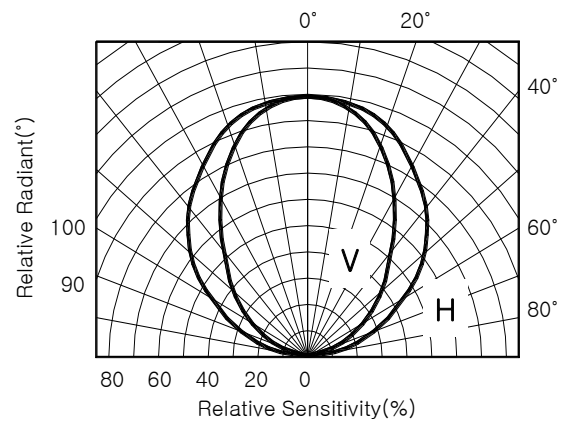

ESD Test Results

Parameter	Conditions	Specification	Results
Machine Model	C=200pF R=0Ω	Min ±200V	>±800V
Human Body Model	C=100pf R=1.5KΩ	Min ±2000V	>±8000V

ESD Testing was performed on Zapmaster System using the Human-Body-Model and Machine-Model according to JESD22-A114D and JESD22-A115-A respectively.

## Appearance & Dimensions

### 1) Package Dimension (Unit : mm)

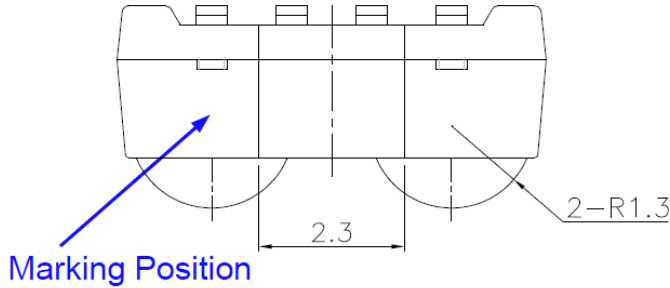

### 1. PIN CONFIG

- ① GND
- ② Vcc
- ③ Vout
- ④ GND

2.G.T ± 0.15

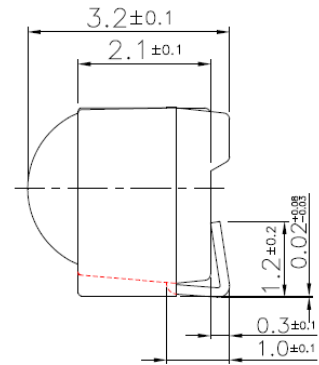
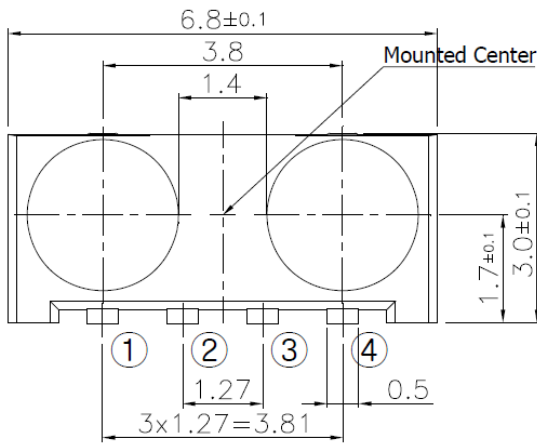

Example of Mounting drawing from Solder Side (Reference)

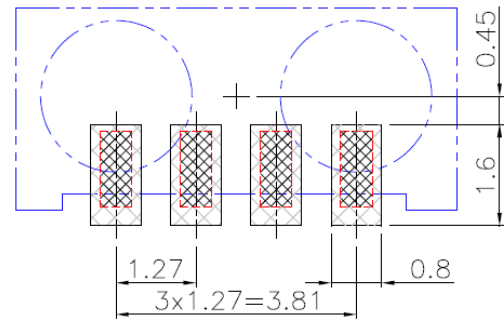
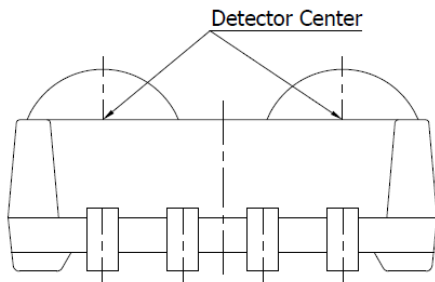

### 2) Marking Position : Package Back Side

### 3) Laser Marking of Method

No.	Classification	Remark
①	Management No.	-
②	Center Freq.	B(36) , C(38) , D(40)
③	Year	0~9
④	Month	1~9 , X(10) , Y(11) , Z(12)
⑤,⑥	Product Lot No.	01~99

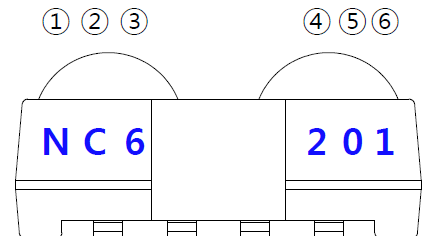

## Reflow soldering

1) Following soldering paste recommended.

    Melting temperature : 245 ~ 260°C

    Composition : Pb-Free

2) Recommended thickness of metal mask is between 0.12mm and 0.15mm for screen printing.

3) The below illustrated temperature profile at the top surface of the product is requested for soldering.

    The components should be limited to a maximum of three passes through this solder reflow profile.

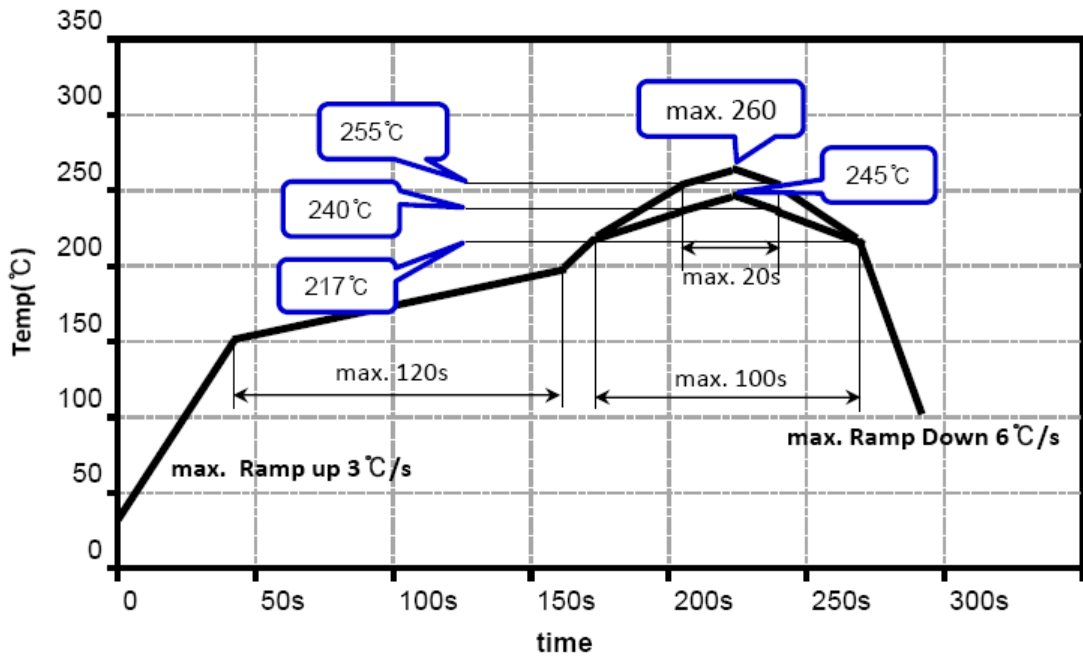

## Manual Soldering

1) Use the Pb-Free solder or the solder containing silver.

2) Soldering iron below 320°C within 3 seconds.

## Cleaning

Perform cleaning after soldering strictly in conformance to the following conditions.

1) Cleaning agent : Alcohol.

2) Temperature and time : 30 seconds under the temperature below 50°C or 3 minutes below 30°C.

3) Ultrasonic cleaning : Below 20W.

### Moisture-Proof Packing

- 1) To avoid moisture absorption by the resin, the product the product is packed in an aluminum envelope with silica gel.
- 2) Since the optical characteristics of the device may be affected by exposure to moisture in the air before soldering and they should therefore be stored after opening the moisture proof bag under the following conditions.
  - . Temperature : 10 to 30°C
  - . Humidity : 60% RH or less
  - . Time : 72h
- 3) Moisture Sensitivity Level (MSL) = 4



### Baking

Product that has been in a condition of moisture resistant packaging for 6 months or longer. or for which 72 hours or longer have elapsed since the moisture resistant packaging was opened. should be baked according to the following conditions prior to use.

- 1) Backing conditions
  - . 60°C , 48 hours or longer (Reels)
  - . 100°C , 4 hours or longer (Bulk)
  - . 125°C , 2 hours or longer (Bulk)
  - . 150°C , 1 hours or longer (Bulk)

### Mounting Precautions

- 1) Do not apply stress to the resin at high temperature.
- 2) The resin part is easily scratched, so avoid friction with hard materials.
- 3) When installing the assembly board in equipment, ensure that this product does not come into contact with other components.

The MSL is an indicator for the maximum allowable time period (floor life time) in which a moisture sensitive plastic device, once removed from the dry bag, can be exposed to an environment with a maximum temperature of 30 °C and a maximum relative humidity of 60% RH. Before the solder reflow process.

Level	Floor Life (out of bag) at factory ambient ≤30°C/60% RH or as stated
1	Unlimited at ≤30°C/85% RH
2	1 year
2a	4 Week
3	168 hours
4	72 hours
5	48 hours
5a	24 hours

Please note : MSL 5a classified devices come in standard pack material, not in dry bags.

### Reliability Test Item and Standard

- 1) All output products shall satisfy below Reliability test items.
- 2) Related sampling quantity and acceptance / failure judgment standard accordance with MIL standard MIL-STD-883 is as listed below.

- ① Confidence level : 90%
- ② LTPD : 10% / 20%

No.	Test Item	Test Conditions	Judgment Standard	Fail (c) / Samples (n)
1	High Temp. Storage (※2)	Ta=+80°C, t=500hr	Vcc=5.0V  High level output voltage VOH > 4.5V  Low level output voltage VOL < 0.4V  Consumption current Icc < 0.5mA  Arrival Distance D > 20m	C=0 / n=22
2	Low Temp. Storage (※2)	Ta=-25°C, t=500hr		C=0 / n=22
3	High Temp. Operating (※1,※2)	Ta=+85°C, Vcc=5.0V t=500hr		C=0 / n=22
4	Low Temp. Operating (※1,※2)	Ta=-20°C, Vcc=5.0V t=500hr		C=0 / n=22
5	High Temp. / High Hum. Bias (※1,※2)	Ta=+80°C, 85%RH Vcc=5.0V, t=500hr		C=0 / n=22
6	Temperature Cycle (※2,※3)	Ta=-20°C (0.5h) to +75°C (0.5h) 20cycle		C=0 / n=22
7	P.C.T (※2)	Ta=+121°C 100%RH P=1atm, t=4hr		C=0 / n=22
8	Solder Heat (※2)	Ta=+320±5°C, 3s		C=0 / n=11
9	Variable frequency Vibration(※2)	Frequency range : 10 to 55Hz/sweep 1min Overall amplitude : 1.5mm X,Y,Z / 2h each		C=0 / n=11
10	Falling (※4)	Height=75cm, 3 times		C=0 / n=11
11	Solder ability (※5)	Soldering Temp. : +260±5°C, 10s, 3 times Pb free solder : Sn/3.0Ag/0.5Cu		Leads shall be covered By solder more than 95%

- ※1. Supply voltage of load test is 5V. (Standard Jig of Opto-Sensor)
- ※2. Electro-optical characteristics shall be satisfied after leaving 2 hours in the normal condition.
- ※3. Temperature cycle test shall repeat above condition 20 times under no load.

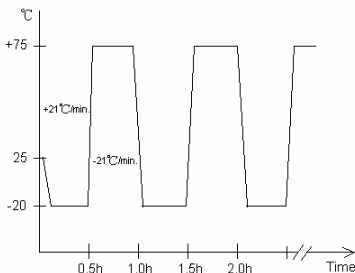

\*Temperature Cycle: Ta = -20°C (0.5h), +75°C (0.5h), 20cycle

\*Temperature Variation rate: +21°C /min, -21°C /min.

- ※4. The test devices shall be dropped three time on the hard wooden board from a height of 75cm.
- ※5. Reflow Soldering.

☞ In cased any trouble or question arises related to above test items, both parties agree to make full discussion and covering the said matters.



Tape and Reel Packing Specifications (Unit : mm)

1. Shape and Dimensions of Reels

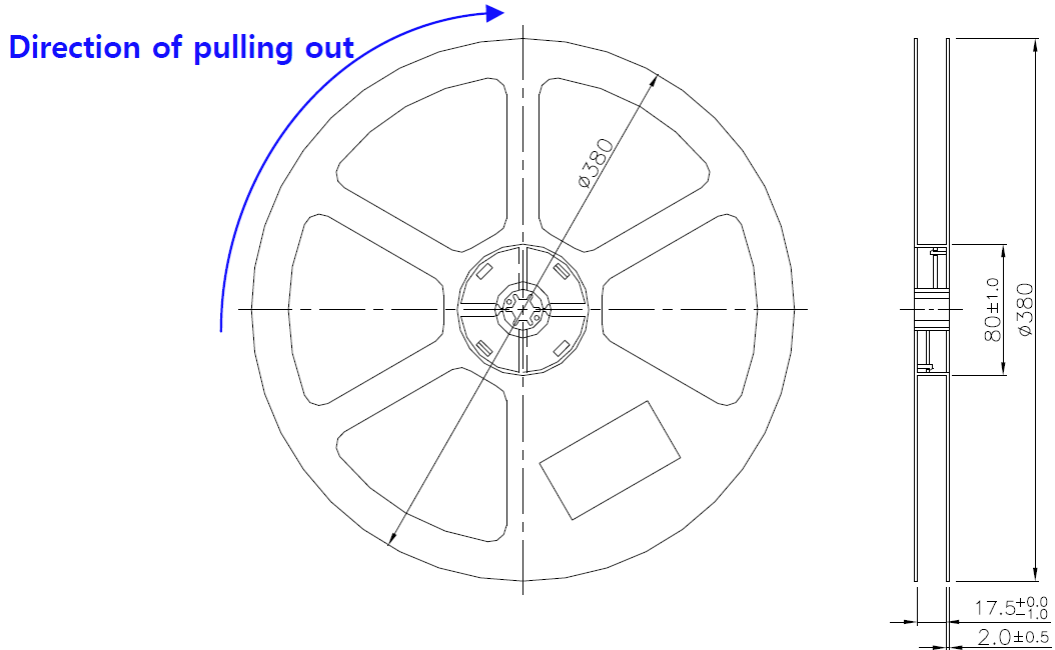

2. Dimension of Tapes

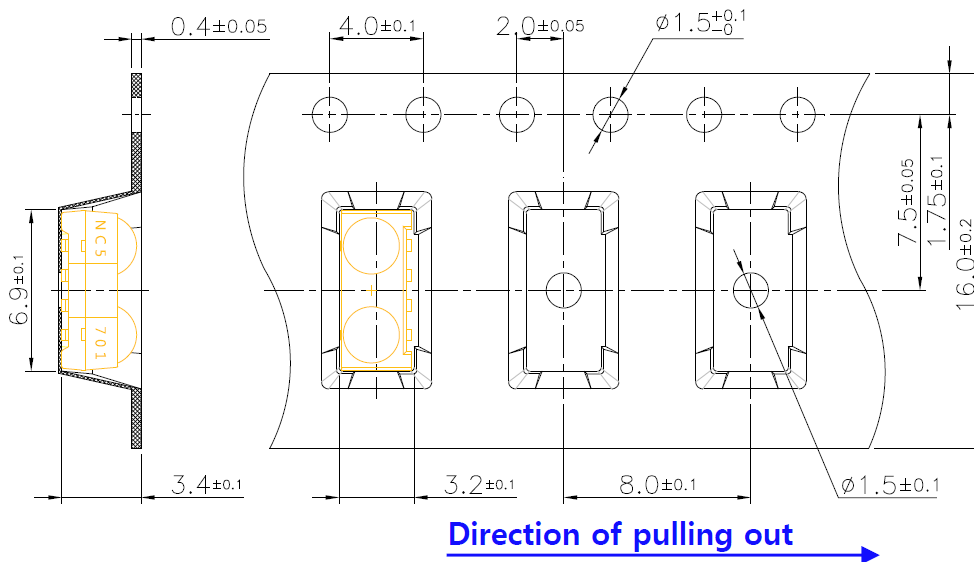

3. Configuration of Tapes

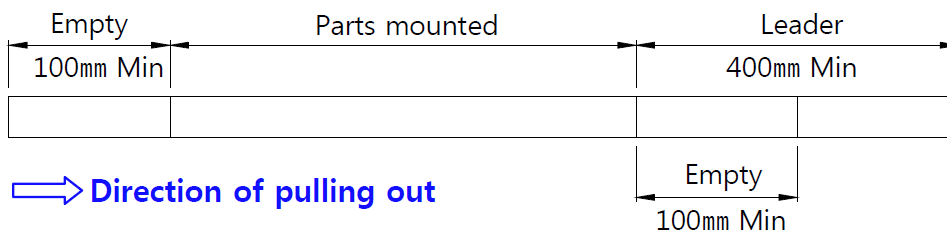

### Packing Specifications

#### 1) Label Specification (Bar Code Sticker)

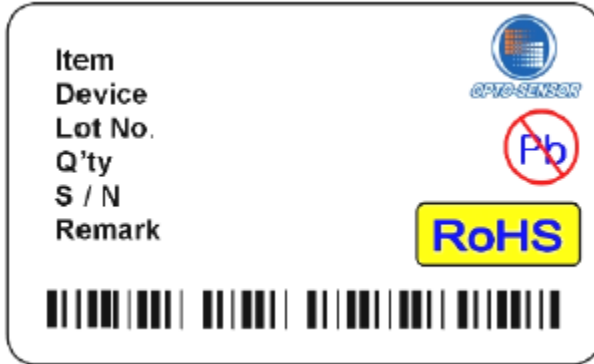

Label Dimensions (Unit : mm)

Label Type	L	W	Remark
Label #1	65	40	

#### 2) Box Specifications & Packing Method

(Unit : mm)

Packing Type	Materials	L x W x H	Quantity
Plastic Reel	Plastic	15" – 16mm	3,600 pcs
Al Shielding Bag	Aluminum	420 x 530 x 0.1	3,600 pcs
BOX-#1	Corrugated Cardboard	400 x 315 x 405	46,800 pcs
BOX-#2	Corrugated Cardboard	660 x 425 x 430	93,600 pcs



1. Put 3,600pcs of products in a reel.



2. Vacuum packing of reel with Al Shielding Bag

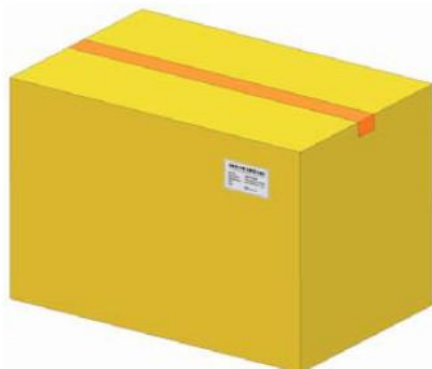

4. Put 2pcs #1 packing box in a #2 packing box.



3. Put them(13pcs of reel) in a #1 packing box.