

## IR Receiver Modules for Remote Control Systems

### Description

The **FM-94□□FF-5DN** is miniaturized receiver for infrared remote control system.

The PIN Photodiode and preamplifier are assembled on lead frame. The epoxy package is designed as IR filter. The module has excellent performance even in disturbed ambient light application and provides protection against uncontrolled output pulses.



### Features

- Transfer Mold Package.
- Supply Voltage Range: 2.7V to 5.5 V
- Supply Current : 0.4mA
- Epoxy IR filter characteristic : 940nm
- Maximum interference safety against optical and electrical disturbance.
- Internal filter for a high frequency lighting fluorescent lamp.
- Internal Pull-Up output.
- Meet RoHS

### Application Circuit

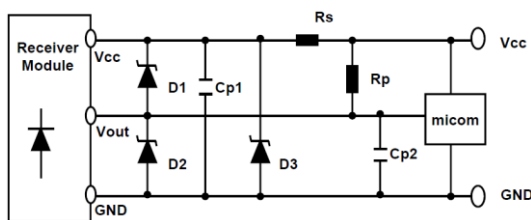

Component	Recommend
1) RS	Typ. 100Ω (47Ω~220Ω)
2) Cp1	Typ. 4.7uF (4.7uF~47uF)
3) Rp	Optional (10kΩ or more)
4) Cp2	Typ. 1nF (1nF~10nF)
5) D1~D3	Zener diode or TVS (ESD Protection device)

Note:  
A further influence to the IR receiver modules may come from a supply voltage which is not stable. Such a disturbed supply voltage can be caused by switching power supply, which is not filtered well or by other components in the circuit which produced spikes on the supply line. This disturbed supply will reduce the sensitivity of receiver modules. This application circuit will filter the disturbed supply voltage.

### Block Diagram

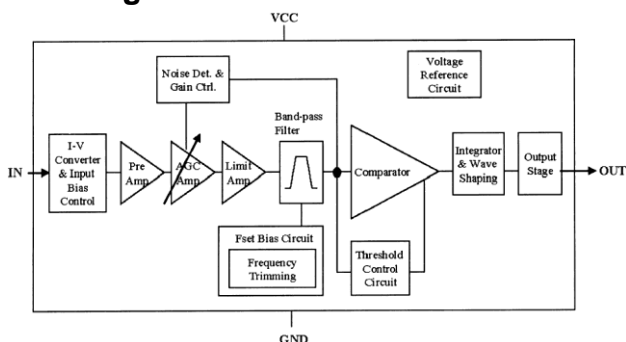

### B.P.F Center Frequency

Model No.	Carrier Frequency (fo)
FM-9436FF-5DN	36.7 KHz
FM-9438FF-5DN	37.9 KHz
FM-9440FF-5DN	40.0 KHz
FM-9456FF-5DN	56.7 KHz

### Suitable Data Format

NEC code	◆	RCMM code	◇	Sony 12-bit code	◆
RC5 code	◆	RCS-80 code	◇	Sony 15-bit code	◆
RC6 code	◆	R-2000 code	◆	Sony 20-bit code	◇
Grundig code	◆	RCA code	◆	High data rate code	◇
Sharp code	◆	Zenith code	◆	Disturbance suppression	◆

◆ : Suitable for this IR code ; ◇ : Not recommended

The data signal should full-fill the following condition :

- Carrier frequency should be close to center frequency of the band-pass.
- Burst length should be 300us/burst or longer.
- After each burst a gap time of at least 300us is necessary.
- The data format should not make a continuous signal transmission.
- There must be a Signal Gap Time (longer than 23 ms) at least each 100 ms, or each data command.

### Absolute Maximum Ratings

(Ta = 25°C)

Parameter	Symbol	Ratings	Unit
Supply Voltage	V <sub>cc</sub>	6.5	V
Supply Current	I <sub>cc</sub>	3.0	mA
Output Current	I <sub>sink</sub>	2.5	mA
Operating Temperature	T <sub>opr</sub>	-20 ~ +80	°C
Storage Temperature	T <sub>stg</sub>	-30 ~ +85	°C
Soldering Temperature	T <sub>sd</sub>	260°C, Max 5 sec	°C

### Electro-optical Characteristics

(Ta = 25°C)

Parameter	Symbol	Min.	Typ.	Max.	Unit	Conditions	
Supply Current	ICC	0.25	0.37	0.50	mA	No signal	
Output Voltage	V <sub>oh</sub>	V <sub>cc</sub> -0.5	-	-	V		
	V <sub>ol</sub>	-	0.2	0.4	V		
Peak Wave Length	λ <sub>p</sub>	-	940	-	nm		
Internal Pull-up Resistor	R <sub>pul</sub>	-	40	-	kΩ		
Center frequency	f <sub>o</sub>	-	37.9	-	kHz		
BPF Bandwidth	f <sub>bw</sub>	2.5	4.5	6.5	KHz	-3dB Bandwidth	
Arrival Distance	L	±0°	12	-	-	m	Fig 1,2,3
		±30°	10	-	-	m	
		±45°	8	-	-	m	
Output Pulse width	T <sub>pw</sub>	400	600	800	us	Burst Wave =600us Period = 1.2ms	

Note :

- 1) Arrival Distance Effected by Environment
- 2) While the device is operational across the temperature range, functionality will vary with temperature. Specifications are stated only at 25°C unless otherwise noted.
- 3) Stresses beyond those listed under "absolute maximum ratings" may cause permanent damage to the device. These are stress ratings only, and functional operation of the device at these or any other conditions beyond those indicated under "recommended operating conditions" is not implied. Exposure to absolute-maximum-rated conditions for extended periods may affect device reliability.

[ Fig.1 ] Data Signal diagram

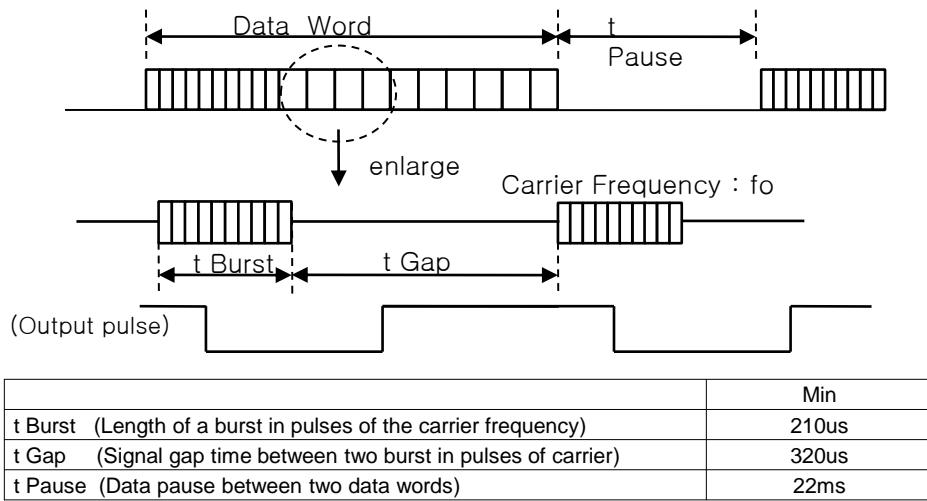

[ Fig.2 ] Transmitter

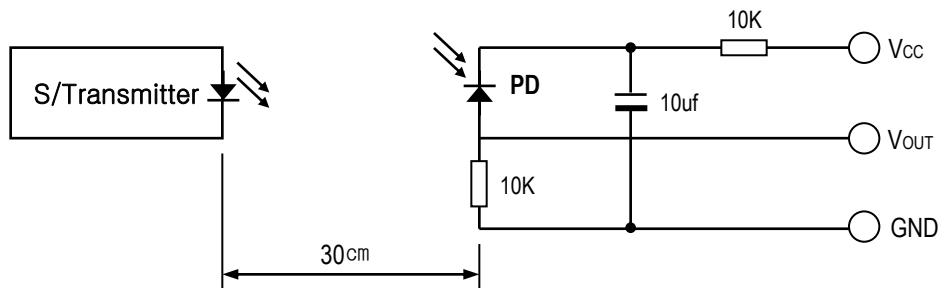

※ The specifications shall be satisfied under the following conditions. The standard transmitter shall be specified of the burst wave form adjusted to  $V_{out}$  200mVp-p upon  $P_o$  measuring circuit Standard Transmitter

[ Fig.3 ] Test condition of arrival distance

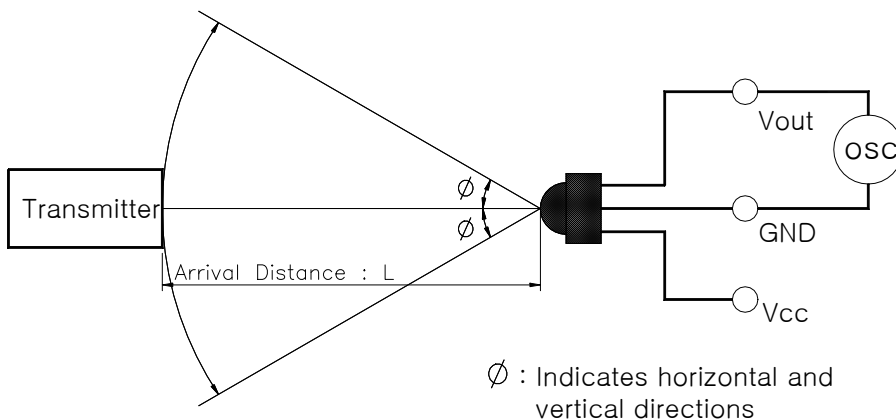

[ Measurement condition for arrival distance ]

☞ Ambient light source : Detecting surface illumination shall be irradiate  $200 \pm 50$  Lux under ordinary white fluorescence lamp without high frequency lighting

### Electrical/Optical Characteristics

[ Fig.4 ] Supply Current vs. Voltage

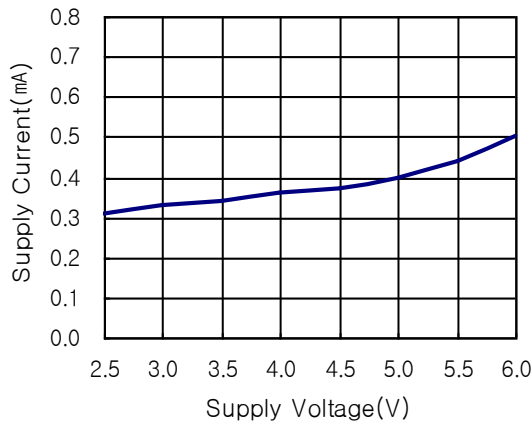

[ Fig.5 ] Relative Spectral Sensitivity vs. Wavelength

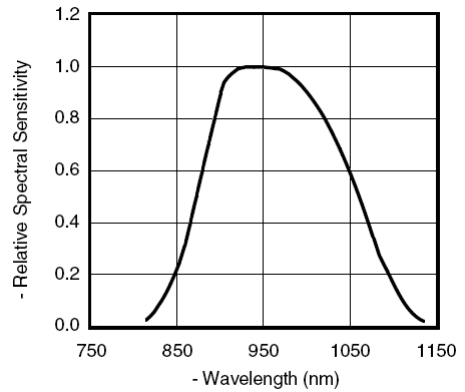

[ Fig.6 ] Sensitivity vs. Supply Voltage

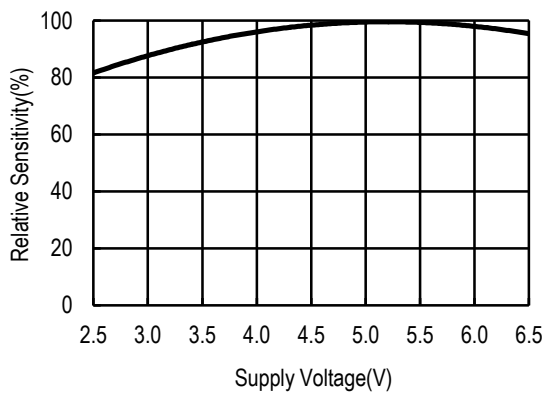

[ Fig.7 ] Directivity

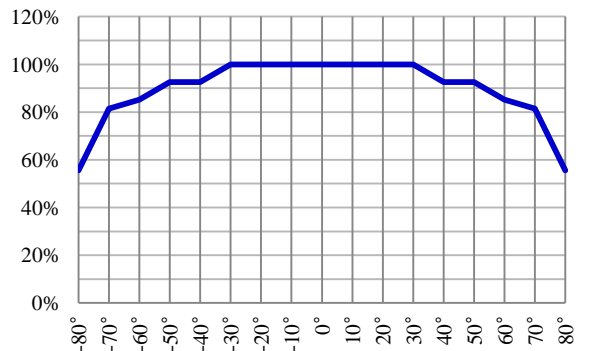

### ESD Test Results

Parameter	Conditions	Specification	Results
Machine Model	C=200pF, R=0Ω	Min ±200V	>±200V
Human Body Model	C=100pF, R=1.5kΩ	Min ±2000V	>±2000V
Charged Device Model	R=100MΩ, R=1Ω	Min ±400V	>±400V

## Appearance & Dimensions

Package Dimension (Unit : mm)

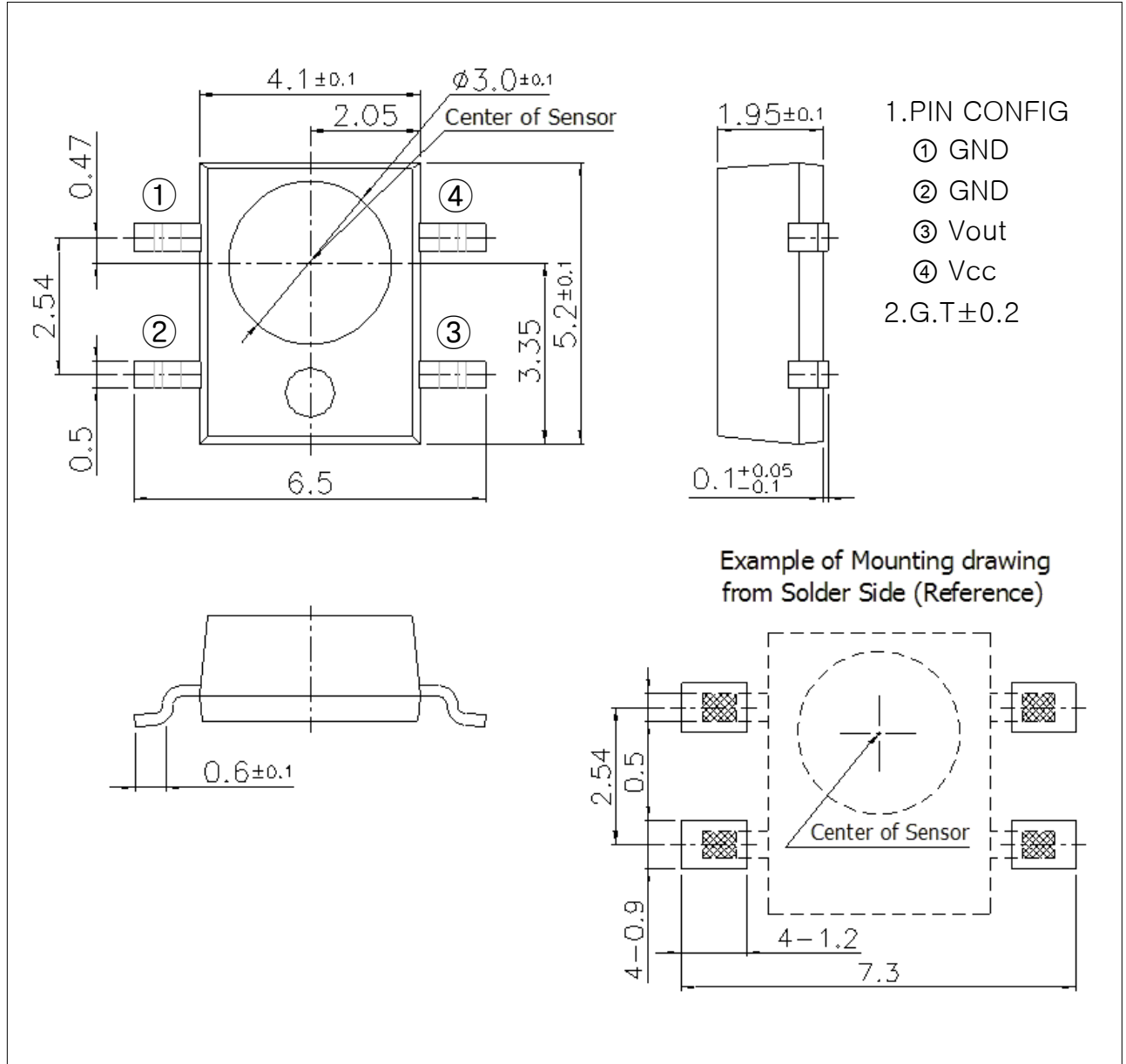

## 2) Back side Laser Marking of Method

No.	Classification	Remark
①	Management No.	J(5DN) , G(5DX) , S(5DRS)
②	Center Freq.	A(32) , B(36) , C(38) , D(40) , E(56)
③	Year	0~9
④	Month	1~9 , X(10) , Y(11) , Z(12)
⑤,⑥	Product Lot No.	01~99

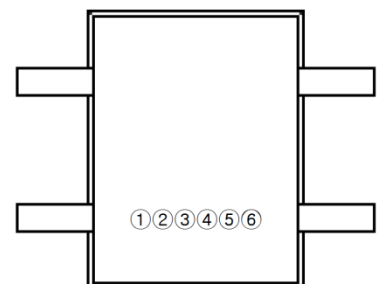

**Tape and Reel Packing Specifications** (Unit : mm)

**1. Shape and Dimensions of Reels**

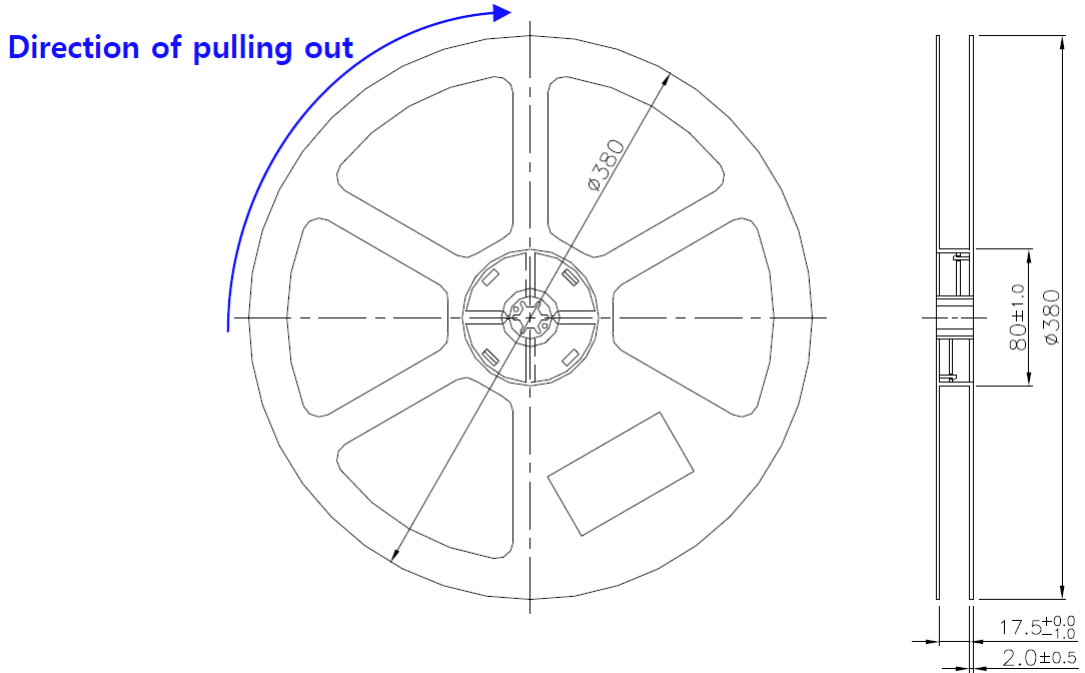

**2. Dimension of Tapes**

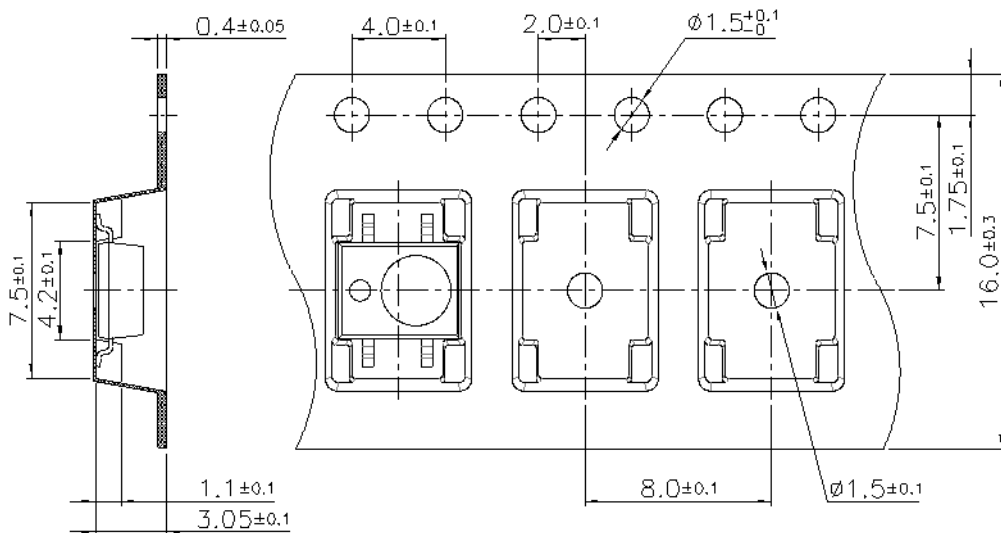

**3. Configuration of Tapes**

